

Three-Stage Combustion Demonstration Projects Update

ClearStack Combustion Corporation

Bob Ashworth
Ed Zawadzki
Fred Murrell

Illinois Department of Human Services

Don Shroyer

Southern Illinois Power Cooperative

Todd Gallenbach

Abstract

In early 2000, the U.S. EPA will likely require coal-fired power plants in Eastern and Mid-Western States to reduce NO_x emissions to 0.15 lb/10⁶ Btu during the summer ozone season and maybe all year long. Currently, Selective Catalytic Reduction (SCR) is the only technology that can meet this low NO_x limit, but it is an expensive fix and certain flue gas components will deactivate the catalyst. ClearStack is developing two three-stage combustion techniques (*Ashworth Combustor*TM and *Stage3Cyclone*TM) to provide the electric utility industry with reliable and low cost options to meet the new limit. In both techniques, the first stage is operated at a stoichiometric air:fuel ratio (SR) of 0.60 to prohibit NO_x and NO_x precursor formation. The second stage is operated at a SR of 0.90 to reduce NO_x to N₂. The third stage is operated at a SR of 1.10 to 1.20 after the furnace gases have cooled to minimize thermal NO_x formation. With three-stage combustion, flame kinetic modeling shows that NO_x emissions can be reduced to below 0.15 lb/10⁶ Btu. Further, these three-stage techniques show significant technical/economic advantages over SCR.

The *Ashworth Combustor* is a pulverized coal-fired system that reduces the three major air pollutants (NO_x, SO₂ and particulate) associated with coal combustion. A 50 million Btu/hr combustion system will be retrofitted to a stoker boiler at the Lincoln Development Center in Lincoln, Illinois. Startup and testing are scheduled for mid 2000. With this technology, a two-stage slagging combustor is used with furnace over-fire air (the third stage). Pulverized coal/limestone are fired/calcined in the combustor. Limestone (lime) is added to flux the slag and capture sulfur in a molten slag eutectic as a non-leaching calcium sulfide. Beside deep NO_x reduction, 70%+ SO₂ and 70 to 80% particulate reductions are projected for the *Ashworth Combustor*. ClearStack, the Illinois Department of Commerce and Community Affairs - *Office of Coal Development and Marketing* and the Ohio Coal Development Office (OCDO) are sponsoring the *Ashworth Combustor* demonstration.

The *Stage3Cyclone* is a simple retrofit to cyclone-fired boilers to reduce NO_x emissions to low levels. The existing cyclone barrels are used as the first stage of combustion and the conventional cyclone feed coal size (- ¼ inch) is used. Limestone is added to flux the coal ash. Second stage air is added in the furnace at the re-entrant throat level followed by over-fire air (OFA) injection in the upper part of the furnace. The technique is to be demonstrated on a Southern Illinois Power Cooperative 33 MWe cyclone-fired unit in Marion, Illinois. Funding arrangements are being made and testing is projected for late 2000.

INTRODUCTION

ClearStack Combustion Corporation's three-stage combustion techniques will reduce NO_x emissions to meet future U. S. EPA limits for coal-fired boilers in Eastern and Mid-Western States. A three-stage *Ashworth Combustor*TM system is currently under construction in Lincoln, IL. With this technology, the three major air pollutants (NO_x, SO₂ and particulate) from coal combustion are significantly reduced. Flame kinetic modeling shows that with three-staged combustion NO_x emissions can be reduced to below 0.15 lb/10⁶ Btu. ClearStack has a host site agreement with Southern Illinois Power Cooperative to demonstrate their *Stage3Cyclone*TM on their Marion Unit #3, a 33 MWe cyclone-fired boiler. Funding is being arranged for this project and it is planned for startup in late 2000.

ASHWORTH COMBUSTOR

The *Ashworth Combustor* includes two complimentary combustion techniques. A two-stage combustor owned by Florida Power Corporation (FPC) that reduces sulfur and nitrogen oxide emissions. It is protected under U. S. Patents 4,395,975; 4,423,702; and 5,458,659 and several foreign patents. ClearStack has exclusive worldwide licensing rights to the FPC technology. The second technology is a three-stage combustion technique, owned by ClearStack, that achieves ultra-low NO_x emissions. It is protected under U. S. Patent Application - Serial Number 243,501.

Background

The FPC two-stage combustor is a small coal gasifier that replaces existing burners. Alkali is added to capture sulfur as CaS in a molten slag eutectic. It incorporates certain features of the Rummel molten slag bath gasifier, an oxygen-blown unit that produced a synthesis gas for hydrogen and ammonia production. The Rummel gasifier, burning German Brown coal (high alkali ash) was found to capture 70% of the coal sulfur in the molten slag removed from the gasifier.

A FPC two-stage pilot unit (12 million Btu/hr) was tested at the Foster Wheeler Development Center (FWDC) in Livingston, New Jersey¹. The thrust of the work was to improve coal gasification rates. Work centered on burner modifications and steam injection to increase gasification rates and provide a more reducing condition in the first stage of combustion. The purpose of creating a more reducing condition was to enhance sulfur capture in the alkaline molten slag.

For most test runs, sulfur reduction was primarily the result of SO₂ being captured by the alkaline fly ash. However, in one run when using a hydrated lime, a five-fold increase in sulfur capture (CaS) by the slag was observed. At that time, 58.8 wt.% overall coal sulfur was being captured. Following pilot testing, the combustor was evaluated to determine why greater percentages of sulfur were not captured in the alkaline molten slag. Some eighty chemical reactions (solid-gas and gas-gas) were evaluated thermochemically to determine what reaction(s) were interfering with the prime sulfur capture reaction:

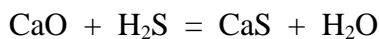

Based on analysis of the possible sulfur specie reactions that could take place in the combustor, the interfering reaction was found. It is as follows:



The premise that this reaction was interfering with sulfur capture is supported by test data. In one run, using a specific coal nozzle, no H₂S, COS or SO₂ could be measured in the first stage gas and yet SO₂ was measured in the stack. This observation showed that oxygen in the first stage air must be consumed rapidly so that sulfur, captured as CaS, is not blown out of the slag as diatomic sulfur (S₂). With this insight, the original combustor design was re-visited. It became obvious why air blown gasifiers failed to meet the sulfur capture performance of their oxygen blown counterparts.

Pilot plant NO_x emission rates were low (~ 0.30 lb/10⁶ Btu) considering no special design provisions were included in the second stage of combustion to minimize NO_x production. The new combustion system will use a three-stage combustion technique that further reduces NO_x emissions. The highest particulate capture observed in the pilot combustor was 60 wt. % of the ash plus alkali fed. In the pilot unit, a slotted internal gas baffle was used and slag was blown through the slot into the boiler. The new design eliminates the problem; slag is removed from the bottom center of the first stage.

Ashworth Combustor NO_x Reduction

The *Ashworth Combustor* three stage combustion technique is optimal for the reduction of NO_x. The first stage is operated at a SR of around 0.60. This is best for elimination of NO_x and NO_x precursors [ammonia (NH₃) and hydrogen cyanide (HCN)] from fuel bound nitrogen. Figure 1a shows the equilibrium concentrations of NO_x and NO_x precursors (NH₃ and HCN) as a function of SR. Figure 1b shows laboratory results from the University of Stuttgart² for various air:fuel ratios based on firing coal with 1 wt.% (MAF) N, three seconds residence time, and a temperature of 2372 °F (1300°C). Coal N to NO_x when using a SR of 0.60 is only about 4%. The data show the effect of stoichiometric ratio on fuel bound NO_x formation.

The *Ashworth Combustor* is operated at higher temperatures, so reaction rates are faster and less residence time is required. Fuel gas from the 0.60 SR first stage enters the furnace at a temperature of 2600°F to 2800°F. Second stage partial oxidation takes place here. A low NO_x burner design is used to bring the air:fuel stoichiometric ratio up to 0.90 SR. This SR is similar to that used with Reburn technology. In this zone, NO is further reduced by the following overall reactions:

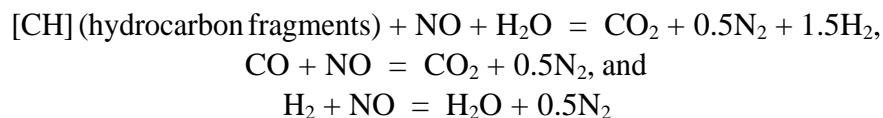

GE-EER completed kinetic modeling³ for the *Ashworth Combustor* and cold flow modeling for the Lincoln unit. The kinetic model held the first stage SR₁ at a value of 0.60 to minimize fuel bound NO_x production. The second stage SR₂ was varied and the third stage SR₃ was held constant at 1.14. In Figure 2, the kinetic model predicts that three-stage combustion will reduce NO_x emissions to less than 0.15 lb/10⁶ Btu of coal fired.

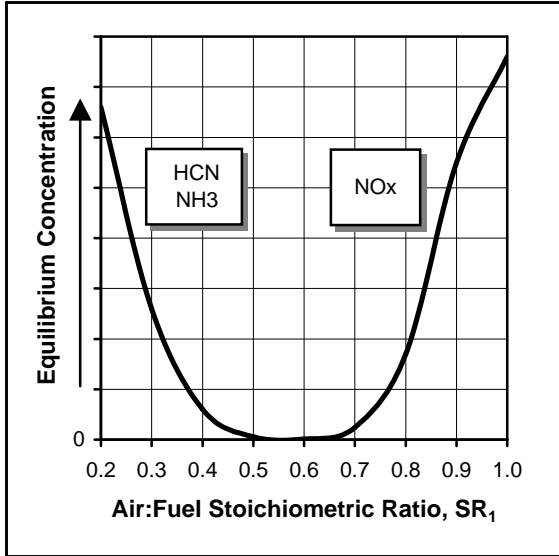

Figure 1a. NO_x Equilibrium Concentration

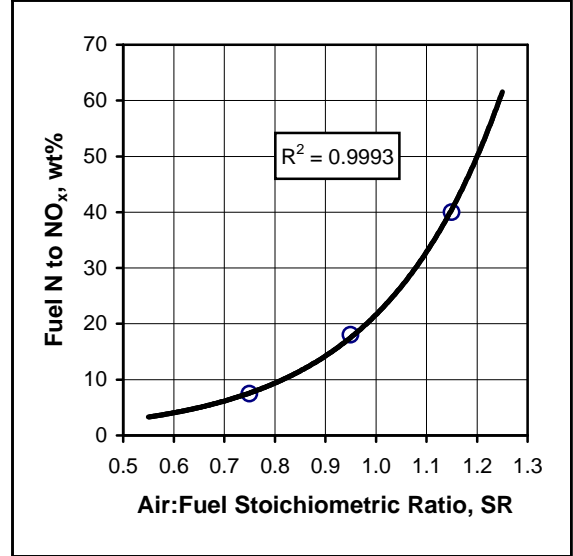

Figure 1b. Fuel N to NO_x Conversion

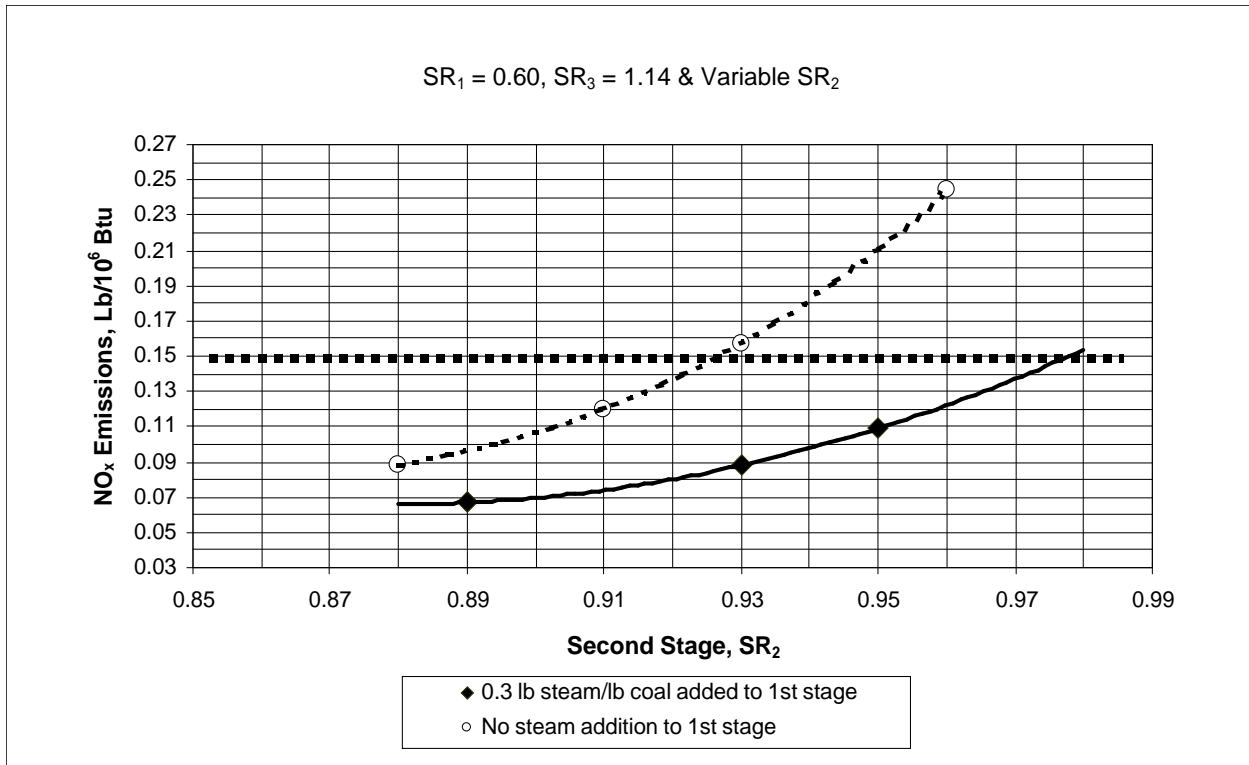

Figure 2. Overall Three-Stage Combustion NO_x emissions.

New Combustor Design

The new design has eliminated recognized design flaws in the pilot combustor. New features are incorporated that yield increased sulfur capture in the molten slag, provide for non-troublesome slag removal, and further reduce NO_x emissions. These parameters have to do with the mode of firing, residence time in the first stage, mode of secondary air introduction, residence time in the second stage (lower part of furnace), and OFA injector design and placement (upper part of furnace). The first stage will also be designed to operate with a conventional wind box pressure level (4 to 6" WC). Based on the new combustor design, the following performance is anticipated:

Sulfur Capture @ Ca/S = 1.0	70 to 90 wt.%
NO _x Emissions	0.07 to 0.15 lb/10 ⁶ Btu
Carbon Conversion	99+ wt.%
Particulate Capture by Combustor	70 to 80 wt.%

Host Site - Lincoln Development Center

The *Ashworth Combustor* demonstration will take place at the Illinois Department of Human Services, Lincoln Development Center in Lincoln, IL. The Center's boiler house has 3 – 50×10⁶ Btu/hr boilers. Units #1 and #3 are coal-fired stoker boilers and Unit #2 is a coal-fired stoker that was converted to natural gas. The Center seldom uses the gas-fired unit due to the higher price of purchased natural gas compared to coal. Unit #2 was therefore selected as the host boiler for the *Ashworth Combustor* retrofit. The retrofit will consist of the following major equipment items; a water-jacketed two-stage combustor, a coal feed system that includes a coal crusher and pulverizer, a (limestone or lime) storage and feed system, a slag quench and removal system, an OFA system, an air pre-heater and a baghouse.

Pulverized coal and limestone (or lime), sized to 70% minus 200 mesh will be fired in the slagging combustor to maintain a SR of about 0.60. Under this reducing or gasification condition, alkaline molten slag will react with coal sulfur to produce a calcium sulfide that will be tied up in a molten slag eutectic. The slag containing CaS will flow through a tap in the center of the combustor into a water-quench drag tank. Testing has shown that the sulfur captured in the slag does not hydrolyze to yield undesirable H₂S. High ash capture in the combustor will be an advantage to units that have electrostatic precipitators (ESPs). Particulate emissions to the atmosphere (including certain air toxics) will be reduced. ESPs are constant efficiency removal devices and with similar fly ash resistivity, as particulate loading to an ESP decreases so does its outlet particulate emissions.

Second stage air is added to the fuel gas (~60 Btu/scf) from the combustor as it enters the boiler furnace to bring the SR up to 0.90. In the upper furnace, OFA is added to bring the SR up to 1.10 to 1.20 to complete the combustion process. To control this staged combustion technique, an innovative and accurate technique that requires only airflow measurements and oxygen concentration at the economizer exit will be used. Flue gas from the boiler flows to a baghouse for particulate removal and then to an atmospheric stack. Figure 3 shows a simplified process flow diagram of the combustor retrofit to Lincoln Development Center Unit #2.

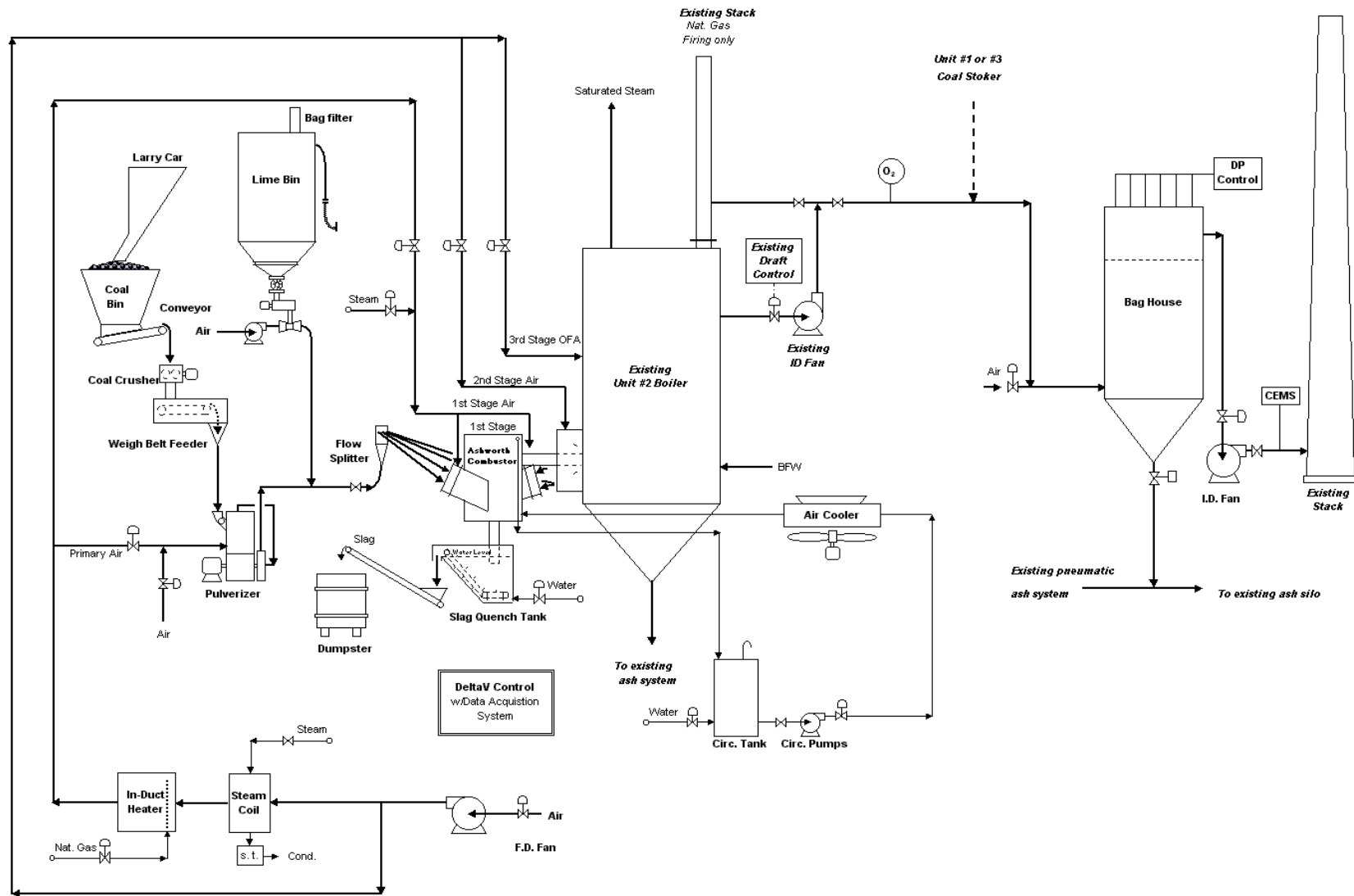

Figure 3. Simplified process flow diagram of Ashworth Combustor retrofit to Lincoln Unit #2.

Lincoln Development Center Test Program

After equipment checkout and startup, the test program will be initiated. It will include the testing of Illinois and Ohio coals. Samples of coal and alkalis used during the tests will be analyzed using ASTM methods. Test measurements and methods are shown in Table 1.

TABLE 1. TEST MEASUREMENTS AND METHODS

Measurement Parameter	Sampling Method	Analytical Method
<u>Raw Materials</u> Coal Limestone Lime/Nacholite Raw material air toxics	Time interval grab samples Grab sample Grab sample Grab sample	Proximate/ultimate anal. Mineral component Mineral component ICP
<u>1st Stage</u> Fuel gas temperature O ₂ and CO concentrations H ₂ S, SO ₂ , COS, NO _x conc. Molten slag carbon/sulfur Molten slag leaching Molten slag: Sulfur & Carbon Air toxics	N/A Suction pump Suction pump Time interval grab samples Time interval grab samples Time interval grab samples Time interval grab samples Time interval grab samples	Thermocouple Draeger Tubes Draeger Tubes Elemental analyzer TCLP X-ray fluorescence X-ray diffraction ICP
<u>Furnace</u> Furnace temperature Fly ash carbon/sulfur Fly ash leaching Fly ash air toxics	N/A Exhaust gas line filter Exhaust gas line filter Exhaust gas line filter	Thermocouple Elemental analyzer TCLP ICP
<u>Air Pollutant Emissions</u> Particulate matter NO _x SO ₂ CO	Heated filter Extractive sample system Extractive sample system Extractive sample system	Gravimetric Chemiluminescent analyzer NDUV analyzer NDIR analyzer

A comprehensive test matrix will be used. The test matrix will be a dynamic one, what is learned from initial testing will be used in later testing to optimize performance regarding sulfur removal and NO_x reduction. Steam injection into the primary air of the first stage will be tested to determine its effect in improving both sulfur capture and carbon burnout. Various first and second stage combustion air:fuel stoichiometric ratios will be tested to evaluate the effect on NO_x reduction and carbon burnout. Elemental carbon and sulfur contents of the bottom ash and fly ash will be run to determine carbon burnout and sulfur capture. In addition, TCLP (toxicity characteristic leaching procedure) analyses will be run on the fly ash and bottom ash to characterize their leaching characteristics. Air toxics for the coal, sorbents, bottom ash and fly ash will be analyzed to determine their final disposition. It will be determined how much of the potential air toxics are captured in combustor molten slag. These air toxic tests, in combination with the TCLP analyses, will characterize emission aspects of the combustor relative to potential air and water-soluble toxics.

As part of the program for OCDO, based on testing at the Lincoln Development Center, an engineering/economic evaluation of retrofitting the *Ashworth Combustor* to a 25 MWe wall-fired unit at the Municipal Power Plant in Orrville, OH will be completed.

STAGE3CYCLONE

The *Stage3Cyclone* is very similar to the *Ashworth Combustor* technique with the exception that the existing cyclone barrels are used as the first combustion stage. The typical feed coal size (minus ¼ inch) is used. Limestone is added to flux the coal ash to maintain a fluid slag under the cooler barrel conditions. The rate of limestone, relative to a specific coal rate, will be set to yield a T_{10} viscosity of around 2600°F. Low NO_x emissions are expected but significant sulfur capture is not, due to the way the air is swirled in the cyclone barrels and the fact that the slag will eventually see the more oxidizing condition of the cyclone furnace. In the cyclone barrels, the coal is gasified using a SR_1 of around 0.60. The fuel gas from the cyclone barrels enters the furnace at a temperature of around 2600°F. The second stage of combustion takes place as the fuel gas passing through the barrel re-entrant throats enters the furnace. Second stage air is added here to bring the SR_2 up to nominally 0.90. The third stage of combustion takes place in the upper part of the furnace after the slightly reducing gas of the second stage has cooled to a temperature that does not favor thermal NO_x production. OFA is added at this point to bring the overall SR_3 up to a typical furnace excess air condition of 1.10 to 1.20.

Stage3Cyclone NO_x Reduction Modeling

ClearStack retained a firm to complete a computational fluid dynamic (CFD) model of the *Stage3Cyclone* technique. Running the cyclone barrels at an SR of 0.60 (first stage), the model predicted that the NO_x emissions from the barrels would be 0.46 lb/10⁶ Btu compared with 0.85 lb/10⁶ Btu for the baseline run using an SR of 1.16. This was a 46% reduction over baseline. Based on furnace modeling results for second and third stage combustion, it was felt that the CFD furnace model used was inaccurate based on what had already been proved commercially. ClearStack is now using cold flow modeling for the furnace.

Host Site – Southern Illinois Power Cooperative (SIPC)

The *Stage3Cyclone* demonstration will take place at Southern Illinois Power Cooperative's Marion Station in Marion, Illinois⁴. The station has four coal-fired cyclone units, Units #1, #2, & #3 have net capacities of 34 MWe each, and Unit #4 is 170 MWe. The *Stage3Cyclone* will be retrofitted to Unit #3. It is equipped with two 7½-ft. diameter cyclone barrels on the front wall of the unit. To retrofit the three-stage combustion technique, the following additions/modifications will be required:

- 1) Addition of limestone bin with feeders (one feed line per barrel)
- 2) Furnace tubewall penetrations
 - Second-stage air
 - Over-fire air
- 3) Installation of second-stage and over-fire air ductwork
- 4) Air flow
 - Air flow sensing and control devices on all air lines
 - Tie-in to existing boiler master control system

The cyclone barrel refractory will be replaced to improve corrosion/erosion resistance. For this unit, secondary air addition will be made through the back wall of the furnace across from the cyclone barrel re-entrant throat openings. Airflow monitors/controls will be added. Existing boiler controls will be modified to incorporate an accurate staged air technique that is based exit furnace O₂ and airflow rates to the three stages. A simplified diagram of the *Stage3Cyclone* is shown in Figure 4.

COMPARISONS WITH SELECTIVE CATALYTIC REDUCTION

The prime driving force for commercialization of the *Ashworth Combustor* and the *Stage3Cyclone* techniques is the NO_x reduction that can be achieved. The only commercially proved method for reducing NO_x emissions to the future EPA (0.15 lb/10⁶ Btu) limit is Selective Catalytic Reduction (SCR). The SCR technology is briefly discussed below.

SCR Technology Discussion

SCR is a post combustion or flue gas treatment technique that includes the addition of ammonia to the flue gas, upstream of beds of vanadium/titanium based catalyst. NO_x (mostly nitric oxide - NO) produced in the boiler furnace is destroyed in accord with the following overall reaction:

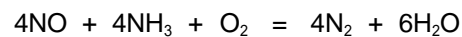

The technique is effective in reducing NO_x emissions; however, it has some serious operational concerns. The catalyst bed is designed to operate within a temperature range of 570°F to 750°F. Above 750°F, the catalyst will sinter, reducing its reactivity. Below 570°F, the ammonium bisulfate will form. The bisulfate can blind the catalyst and shorten its life. This temperature operating range requires that flue gas bypasses be installed around the catalyst bed and economizer. Coals high in calcium (e.g. Western coals) form calcium sulfate that can also blind the catalyst. Further coals high in arsenic (e.g. above 10 ppmw) will deactivate the catalyst and shorten its life. This decreases the coal suppliers that a utility can use. The catalyst can plug with fly ash. In addition, special air heater designs with spray washing features may be required to wash out ammonium bisulfate deposits.

Economic Comparison of SCR, Ashworth Combustor and Stage3Cyclone

Capital and operating costs were developed for retrofits of SCR, the *Ashworth Combustor*, and the *Stage3Cyclone* to a 330 MWe cyclone-fired boiler. The boiler was assumed to have a gross heat rate of 10,000 Btu/kWh and a 65% capacity factor. For the analysis, a baseline level of 1.30 lb NO_x/10⁶ Btu was assumed and emissions after the retrofits was assumed at 0.15 lb/10⁶ Btu. For the *Ashworth Combustor* an SO₂ credit was taken. To account for capital related charges, a fixed charge rate of 12% of the total plant investment (TPI) was assessed. For all three cases, it was assumed that no added operating labor would be required. Based on equipment service considerations, a 2% TPI was charged for annual maintenance for the SCR retrofit and 3% TPI was charged for the *Ashworth Combustor* and *Stage3Cyclone* retrofits. A 10% contingency was added to the SCR retrofit and 15% contingencies were added to the *Ashworth Combustor* and *Stage3Cyclone* retrofits since these techniques have not been commercially applied.

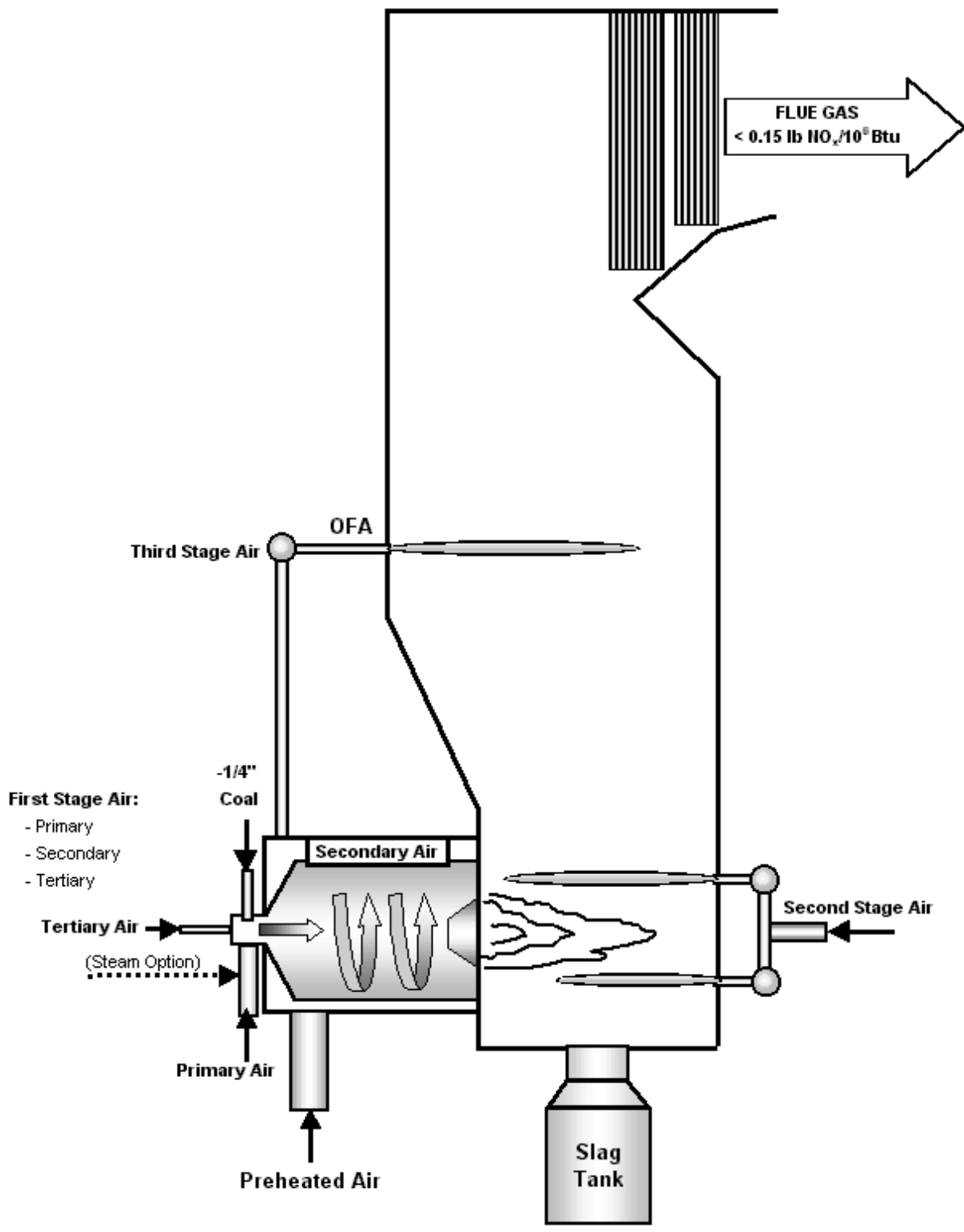

Figure 3. Stage3Cyclone combustion technique.

Table 2 shows the capital and operating cost breakdowns for SCR, the *Ashworth Combustor* and *Stage3Cyclone* retrofits to a 330 MWe cyclone-fired unit. The capital cost for the SCR retrofit was estimated at \$28.6 million or \$87/kWe. The *Ashworth Combustor* retrofit was estimated at \$20.7 million or \$63/kW and the *Stage3Cyclone*, was estimated at \$8.7 million or \$26/kW. The annual incremental operating cost for the SCR retrofit was estimated at \$6.1 million or \$565/ton of NO_x removed. The gross annual incremental operating cost for the *Ashworth Combustor* was estimated at \$4.5 million or \$412/ton of NO_x removed. However, when taking credit for a reduction in SO₂ based on an allowance of \$150/ton there is an annual savings of \$5.1 million that more than offsets the cost of NO_x reduction and an overall net operating savings of \$617,000 per year is realized. The annual incremental operating cost for the *Stage3Cyclone* retrofit was estimated at \$2.0 million or \$185/ton of NO_x removed.

The *Ashworth Combustor* provides a lower cost NO_x control technique than SCR for cyclone units and removes sulfur that provides SO₂ credits. For cyclone units that already have SO₂ scrubbers, the *Stage3Cyclone* technique will be the low cost alternative for reduction of NO_x.

CONCLUSION

The *Ashworth Combustor* and *Stage3Cyclone* techniques have the potential to offer significant technical and economic advantages over SCR. The demonstrations in Illinois in 2000 are designed to show the efficacy of these three-stage combustion techniques for NO_x reduction. In addition, if the *Ashworth Combustor* is as successful as expected in reducing both NO_x and SO₂, the technique will put high sulfur coal squarely back into the energy mix of the future.

References:

1. Ashworth, R. A. and Padilla, A. A., "*CAIRE*" *Advanced Combustor Development*, Ninth Annual International Pittsburgh Coal Conference, Pittsburgh, PA, October 14, 1992.
2. Kluger, Frank, et. al, *Comparison of Coals and Air Stage Combustion with Respect to NO_x Emissions*, 23rd International Technical Conference on Coal Utilization & Fuel Systems, Clearwater, FL, March 9-13, 1998.
3. *NO_x Kinetic Modeling Report*, Energy and Environmental Research Corporation, October 23, 1998.
4. Ashworth, Bob; Zawadzki, Ed; Shroyer, Don; and Gallenbach, Todd, *Three-Stage Combustion NO_x Compliance*, Power-Gen 99, New Orleans, LA, November 30 - December 2, 1999.

TABLE 2. CAPITAL AND OPERATING COST COMPARISON

330 MWe Cyclone-fired Boiler NOx Control Retrofits

<u>Capital Cost:</u> Category	<u>SCR</u>		<u>Ashworth Combustor</u>		<u>Stage3Cyclone</u>	
	\$Millions	Cost/kWe	\$Millions	Cost/kWe	\$Millions	Cost/kWe
Major Equipment	13.2	\$40	7.4	\$23	3.4	\$10
Construction Labor	4.6	\$14	4.1	\$13	1.5	\$5
Construction Indirects	3.7	\$11	3.1	\$9	1.3	\$4
Engineering	1.6	\$5	1.1	\$3	0.5	\$2
Project Management	1.0	\$3	1.1	\$3	0.3	\$1
Taxes, Other	1.4	\$4	0.5	\$2	0.2	\$1
Startup	0.6	\$2	0.6	\$2	0.2	\$1
Subtotal	26.0	\$79	18.0	\$54	7.6	\$23
Contingency	@10% 2.6	\$8	@15% 2.7	\$8	@15% 1.1	\$3
Total Plant Investment	28.6	\$87	20.7	\$63	8.7	\$26
<u>Annual Incremental Operating Costs:</u>						
	<u>Cost</u>	<u>\$/Ton NO_x</u>	<u>Cost</u>	<u>\$/Ton NO_x</u>	<u>Cost</u>	<u>\$/Ton NO_x</u>
	<u>\$K/Year</u>	<u>Removed</u>	<u>\$K/Year</u>	<u>Removed</u>	<u>\$K/Year</u>	<u>Removed</u>
Utilities:						
Electricity	54	\$5	N/A	N/A	N/A	N/A
Catalyst & Chemicals:						
Limestone	N/A	N/A	423	\$39	262	\$24
Ammonia	55	\$5	N/A	N/A	N/A	N/A
Catalyst	932	\$86	N/A	N/A	N/A	N/A
Solids Disposal:						
Catalyst	33	\$3	N/A	N/A	N/A	N/A
Ash w/alkali	N/A	N/A	190	\$18	118	\$11
Fixed Charge Rate @ 12% of TPI	3,438	\$318	2,479	\$229	1,042	\$96
Labor:						
Maintenance	315	\$29	372	\$34	156	\$14
Supervision	63	\$6	74	\$7	31	\$3
Supplies:						
Maintenance	210	\$19	248	\$23	104	\$10
Admin. and Gen. Ovhd. (30% of total labor)	227	\$21	112	\$10	47	\$4
Insurance and Taxes (2.7% of TPI)	774	\$72	558	\$52	234	\$22
Total Gross Operating Cost	6,101	\$565	4,456	\$412	1,995	\$185
SO₂ Allowance Credit @ \$150/ton			(5,073)	(\$470)		
Net Operating Savings			617	\$57		

Notes: 1. 330 MWe @ 65% capacity factor and a 10,000 Btu/kWh gross heat rate. 12,500 Btu/lb coal w/10wt% ash.

2. NOx reduction based on baseline value of 1.30 lb NOx/10⁶ Btu reduced to 0.15 lb NOx/10⁶ Btu

3. Catalyst use based on 32,000 hrs before all initial catalyst has been replaced (Southern Energy Inc. Power-Gen 97 paper)

4. Anhydrous ammonia price FOB plant (\$170/ton), Purchasing Magazine, August 12, 1999 w/\$10/ton shipping charge added

5. Auxiliary power cost assumed at \$0.03/kWhr

6. Ashworth Combustor 3.6 lb SO₂ removed/10⁶Btu of coal fired.

U.S. EPA 12/99 SO₂ credits @ \$150/ton

7. Assumed no incremental operating labor required for these NOx control technique